

**LUDLUM MODEL 44-88 & 44-88-1
CYLINDRICAL PANCAKE DETECTOR**

August 2020

**LUDLUM MODEL 44-88 & 44-88-1
CYLINDRICAL PANCAKE DETECTOR**

August 2020



LUDLUM MEASUREMENTS, INC
501 OAK STREET, P.O. BOX 810
SWEETWATER, TEXAS 79556
325-235-5494, FAX: 325-235-4672

**Model 44-88 & 44-88-1
Cylindrical Pancake Detector**

TABLE OF CONTENTS

1. GENERAL	1
2. SPECIFICATIONS.....	1
3. PARTS LIST.....	2
4. DRAWINGS AND DIAGRAMS	3

Model 44-88 & 44-88-1 Cylindrical Pancake Detector

1. GENERAL

The Model 44-88 and 44-88-1 Cylindrical GM (Pancake) Detectors will detect alpha, beta, and gamma radiation. The two detectors are similar. The only difference is the length of the detector. The detector is energy dependent, over-responding by a factor of 6 in the 60 keV to 100 keV range when normalized to ^{137}Cs .

The thin window is protected by a 79% open stainless steel screen. The GM tube can easily be removed for repair. (Refer to the drawing at the end of this manual for detail of construction and parts.)

The GM detector operates at 850-1000 volts. The tube manufacturer recommends operation at 900 V. The recommended

instrument input sensitivity is approximately 30 mV or higher to keep the detector from double pulsing. The double-pulse is caused by the size of the after-pulse exceeding the instrument threshold.

The GM tube face is also susceptible to rupture above 2438 m (8000 ft) altitude pressure. Consequently, detectors carried in unpressurized aircraft above this altitude would be subject to failure.

The Model 44-88 and 44-88-1 detectors will operate with any of the Ludlum instruments or equivalent instruments that provide 900 V and an input sensitivity of approximately 30 mV or higher.

2. SPECIFICATIONS

- **Operating Voltage:** 900-1100 V (900 V typical)
- **Window Thickness:** 1.7 \pm 0.3 mg/cm² mica
- **Window Area:** 15.5 cm²
- **Window Protective Screen:** 79% open
- **Efficiency (4 π):** 5% for ^{14}C ; 22% for $^{90}\text{Sr}/^{90}\text{Y}$; 19% for ^{99}Tc ; 32% for ^{32}P ; 15% for ^{239}Pu
- **Weight:** 0.22 kg (0.50 lb)
- **Size:**
Model 44-88: 5.9 x 7 cm (2.3 x 2.8 in.) (Dia x L)
Model 44-88-1: 5.9 x 14 cm (2.3 x 5.5 in.) (Dia x L)

**Model 44-88 & 44-88-1
Cylindrical Pancake Detector**

3. PARTS LIST

Model 44-88 & 44-88-1 Cylindrical Pancake Detector

<u>Ref. No.</u>	<u>Description</u>	<u>Part No.</u>
UNIT		
1	Completely Assembled Model 44-88 Cylindrical Pancake G-M Detector	47-2356
	OR	
1	Completely Assembled Model 44-88-1 Cylindrical Pancake	47-2895
1	GM TUBE – (N1006)	01-5273
1	CONNECTOR, UG 706/U	13-7751
1	PROTECTIVE SCREEN	7241-008
1	4-40 x 3/16 FH SCREWS	17-8811
1	LUG-1497	18-8766

**Model 44-88 & 44-88-1
Cylindrical Pancake Detector**

4. DRAWINGS AND DIAGRAMS

Assembly View, Drawing 2 X 329

REV #	ALTERATIONS	DATE	BY
1	VALID	1/28/02	DSW
2	ECF# 2429	10/14/10	CMC

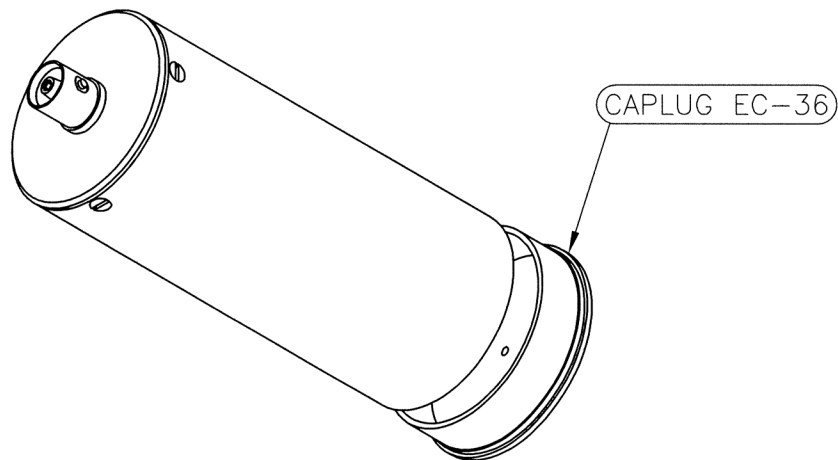
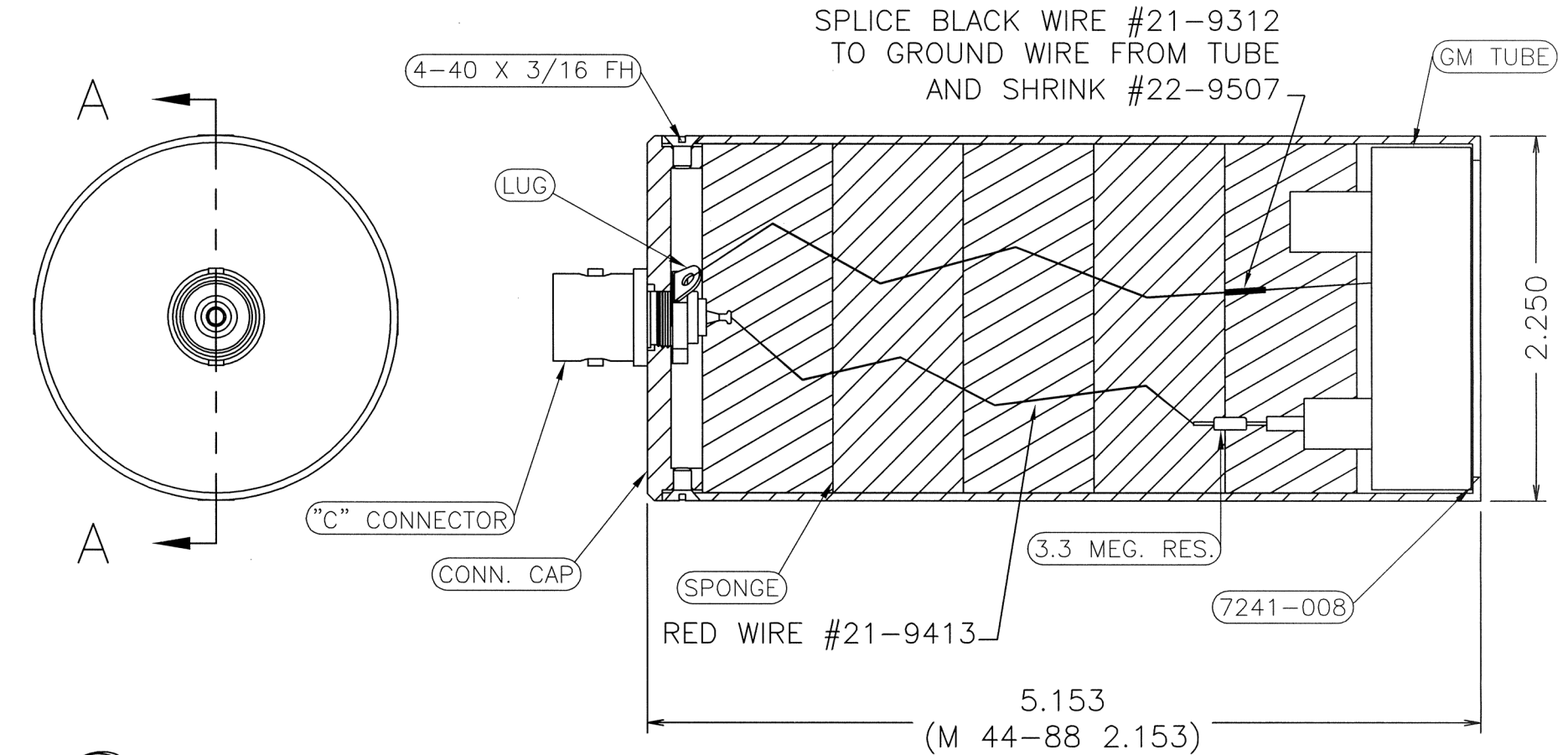

SECTION A-A

NOTE:
M 44-88 USES
3 PCS. OF SPONGE
TO HOLD GM TUBE
IN PLACE

4002-521

DWN WJM	DATE 6/3/14	CHECKED	APPROVED <i>New 6-6-14</i>
TITLE: M 44-88-1 & M 44-88 ASSEMBLY			
LUDLUM MEASUREMENTS, INC. 501 DAK STREET SWEETWATER, TEXAS 79556		SERIES 2	SHEET 329